

MIICRAFT



Advance and Profession series User Manual

May 2019 v1

Printing work flow

This manual focus on the work flow of Printer hardware operation and after printing process.

MIIICRAFT

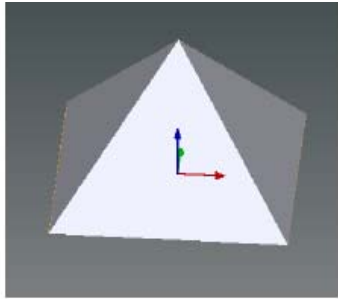

1. Get 3D file (*.stl) from
 - a. CAD
 - b. 3D scanner



3. Printing setting
 - a. Material selection
 - b. Tilt speed
 - c. Printing optimization



2. 3D file preparation
 - a. Repair 3D file
 - b. Build supports
 - c. Slice (Layer thickness)

4. Printer operation
5. After printing
 - a. Post curing
 - b. Remove supports
 - c. Grinding (optional)

Main Content

1. [Printer and Accessory](#)
2. [Safety Precautions](#)
3. [Specification](#)
4. [Power on and off](#)
5. [Remove and install build platform](#)
6. [Fill resin](#)
7. [Change Tank](#)
8. [Clean Teflon Module](#)
9. [Maintenance- Change Teflon film](#)
10. [After printing](#)

Printer and Accessory

MIICRAFT

Check out all the elements in your printer package.

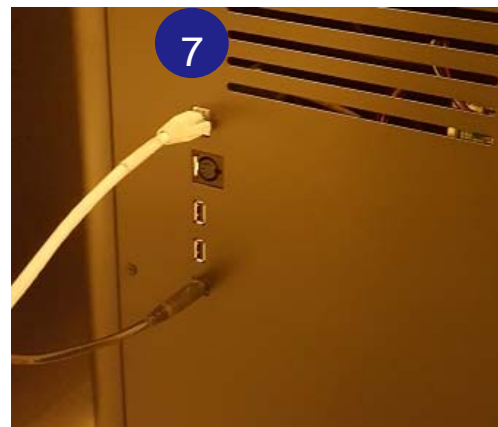
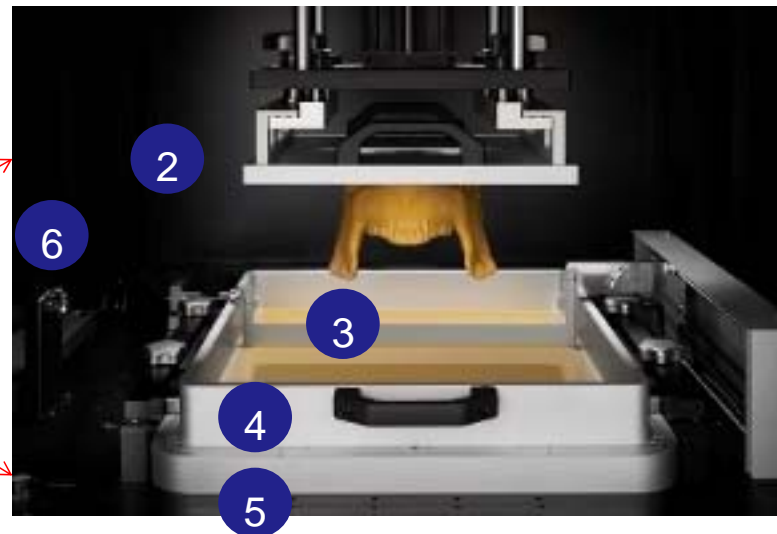

Back

- (1) Touch screen
- (2) Build platform (Picker)
- (3) Recoater blade
- (4) Tank
- (5) Glass holder
- (6) Camera
- (7) I/O
 - RJ-45 port
 - Warning light port
 - USB port
 - Power cord port



Printer and Accessory

Check out all the elements in your printer package.



Accessory box

- (1)Adapter 1 unit
- (2)Cord 1 unit
- (3)Putty knife 1 unit
- (4)M3 Wrench 1 unit
- (5)Plastic plate 1 unit
- (6)Stopper 4 units
- (7)RJ-45 cable

7



Safety Precautions

MIICRAFT

- Please read through the following Safety Precautions before you start using your printer.
- (1) Warning : "Build platform" and "Tank" is hazardous moving parts in MiiCraft Printer. Keep body parts out of picker's motion path.
- (2) Emergency shut down method : Press the power button to shut down. Or unplug the power cord.
- (3) Use only the power adapter provided by the supplier.
- (4) Before plugging the power adapter and cord into an electrical outlet, verify the local power rating conforms with the specified voltage and frequency.
- (5) This printer needs a grounded, 1-phase electrical power source.
- (6) Make sure power and communication cables are well managed to prevent from tripping.
- (7) Do not disassemble or repair the device yourself. Doing so may cause device malfunction or danger.



Safety Precautions

MIICRAFT



- (8) Chemical substances like resin may cause skin irritation, please read the guidelines in Material Safety Data Sheet (MSDS) of the resin supplied by manufacturer. It is recommended to wear gloves when doing the printing process.
- (9) Keep door closed during printing or curing to prevent UV leakage.
- (10) UV light may cause injury of eyes, do not stare into the printer directly when it is in operation. It is recommended to wear UV protective glasses during operating the printer.
- (11) Place the device on a level surface and keep the printer in an upright position at all times, especially in transportation.
- (12) Do not store the printer in extreme hot and cold temperatures.
- (13) Do not expose the resin tank to direct light source because the resin will solidify under UV light. When moving the printer, be sure to take our tank or make sure there's no resin inside the take to prevent resin leakage.



Specification

MIICRAFT

Product Name	Advance 255/205 Profession 250/120
Power Input	With Adapter : 100~240V AC, 2A, 50/60Hz
Net Weight	310 kg
Package Size and Weight	L*W*H 117*107*225 cm / 428 kg (Including pallet) (Package design and size is possibly change)
Operating Temperature	10° to 30°
Humidity (RH)	40% to 60% Our printer should keep in dry conditions
Storage of Printing Material	Store the materials at ambient temperature from 15° to 28° And do not exposure to the light, otherwise resin may solidified
<ul style="list-style-type: none">• Liability: In case you do not follow the operating manual we cannot be held responsible for damages of the machine or injuries on the operator.	



Specification

MIICRAFT

	Advance 255	Advance 205	Profession 250	Profession 120
Building size (mm)	255x235x190	205x185x190	250x140x190	120x67x190
XY Resolution	125um	100um	65um	30um
Type	Dual 1080P	Dual 1080P	4K Ultra HD	4K Ultra HD
Wavelength (LED)	405nm	405nm	405nm/385nm/365nm	405nm/385nm/365nm
I/O	Ethernet / USB / Wifi / Power in, Adapter: 100~240V AC, 2A, 50Hz/60Hz			
Size and Weight	819(W)x750(D)x2000(H) mm / 300kg			



Power on and off

MIICRAFT



Power Button

Power On

Press Power Button => Panel shows Starting up => Panel shows Menu

Power Off

Press Power Button => Confirm message => Confirm to shut down



Remove and Install Build Platform

MIICRAFT



(1) Loosen 2 screws
Turn the screws counterclockwise

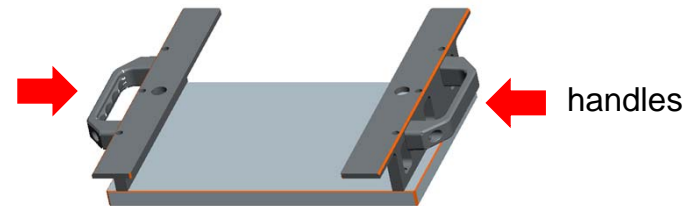

(2) Holding two handles beside the build platform, and slowly pull out the build platform

(3) Be careful to holding the build platform, especially the moment detach from the track



Remove and Install Build Platform

MIICRAFT

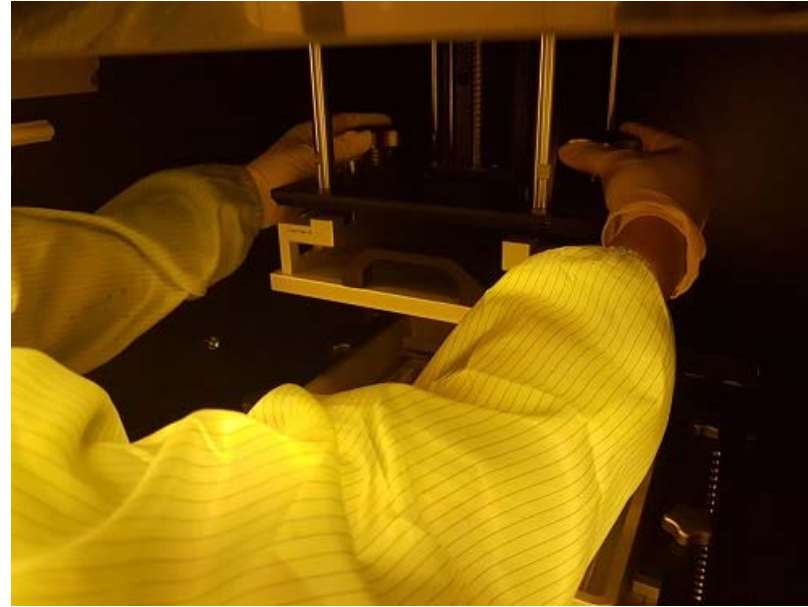
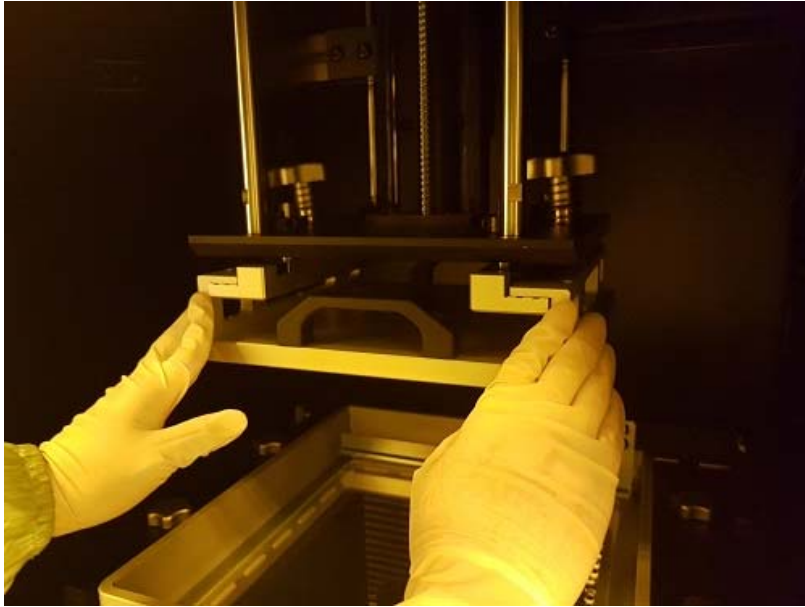

- (1) Put the build platform back, push to the end
- (2) Turn the 2 screws clockwise until tight ---finish



Fill Resin

MIICRAFT

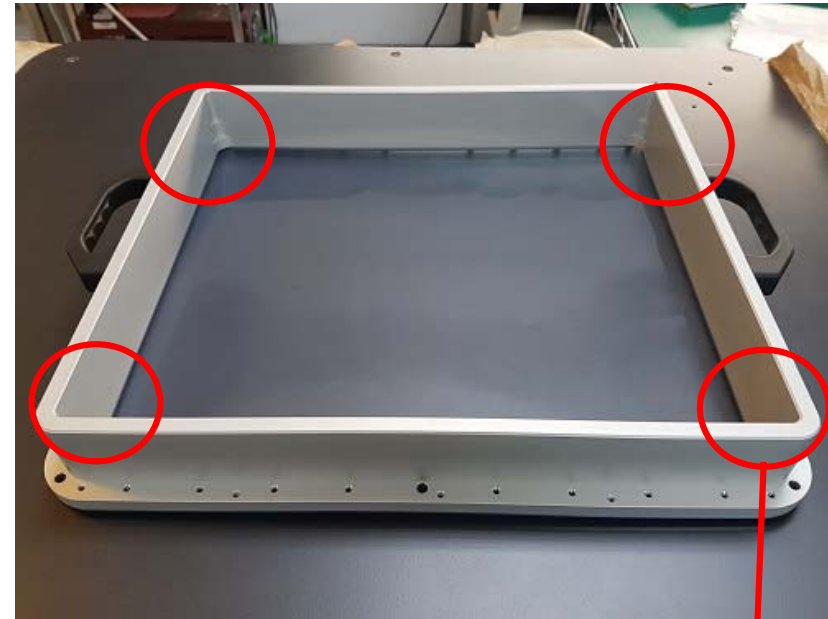
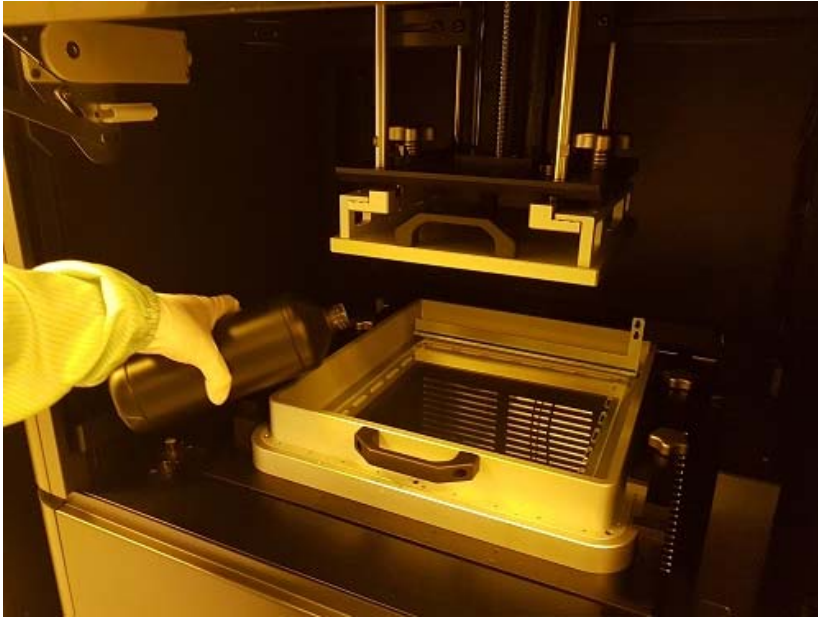

- (1) Fill resin
- (2) Suggest filling height:
Between red line as picture on the right, in the case tank is inside the printer.

If the tank is out of the printer, suggest the resin level slightly lower than red lines.

There are lines scale carved in inner corner of tank (4 place)

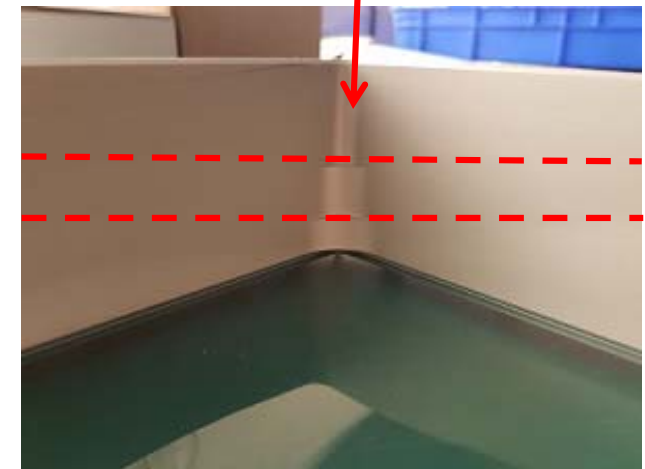

In the case tank is inside the printer



Change Tank

How to take out and install tank module?

MIICRAFT

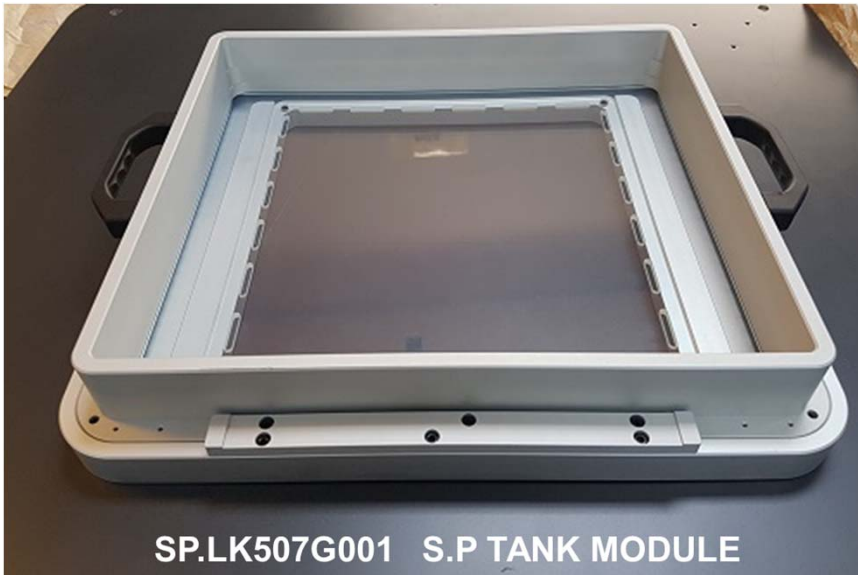

(1) Loosen 4 screws
Turn the screws counterclockwise

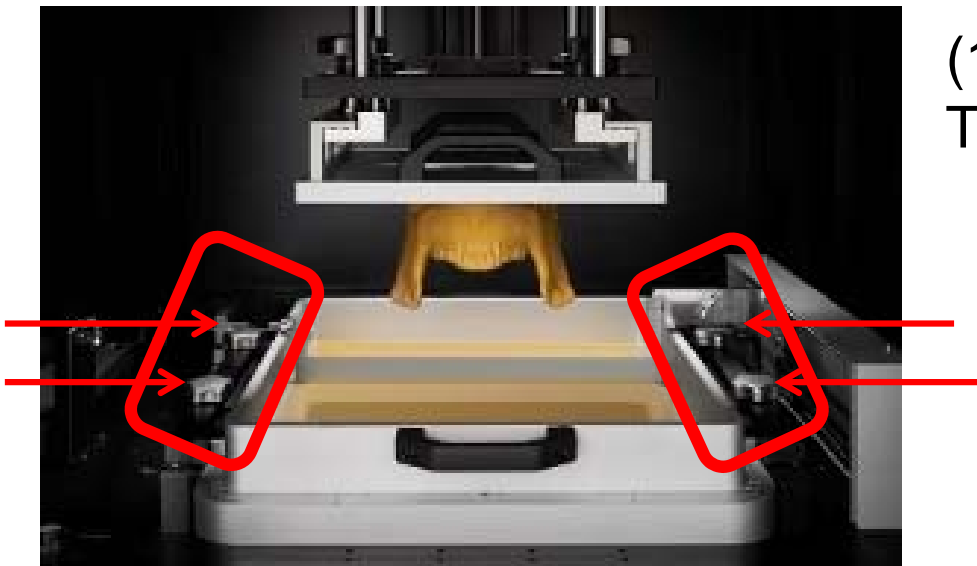

Change Tank

How to take out and install tank module?

MICRAFT

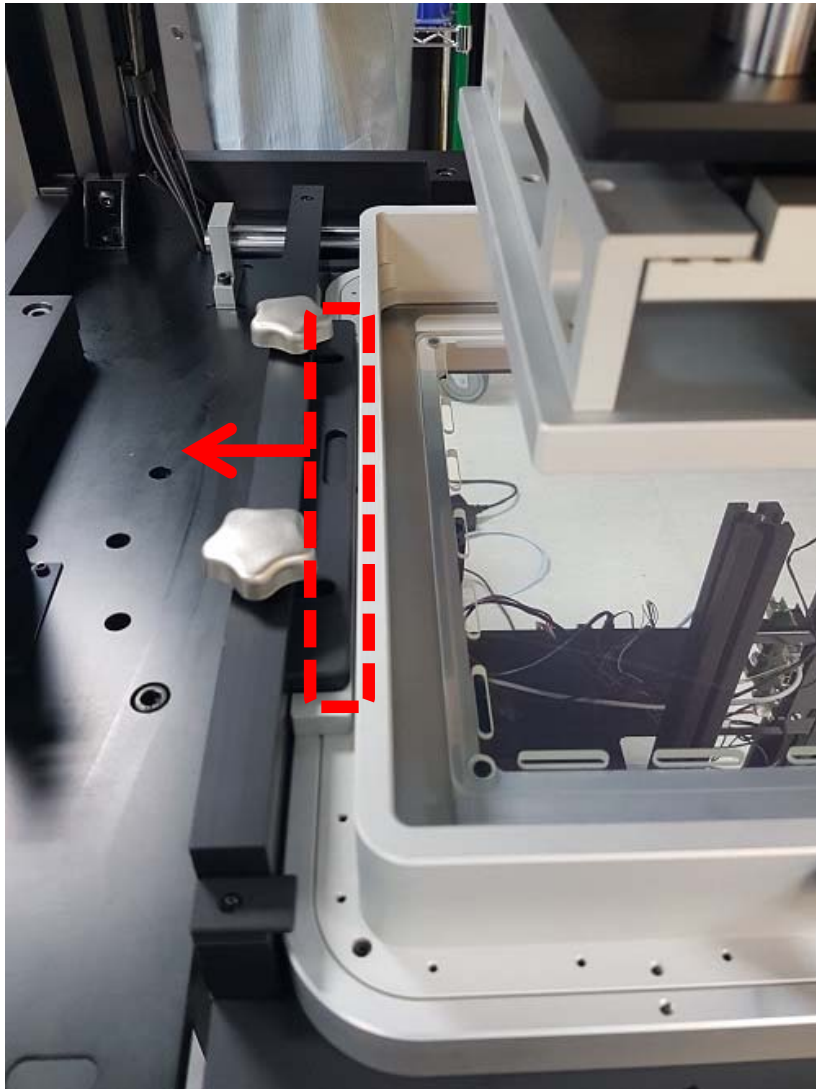

(2) Pull out two side stoppers
(Right and Left side of tank)

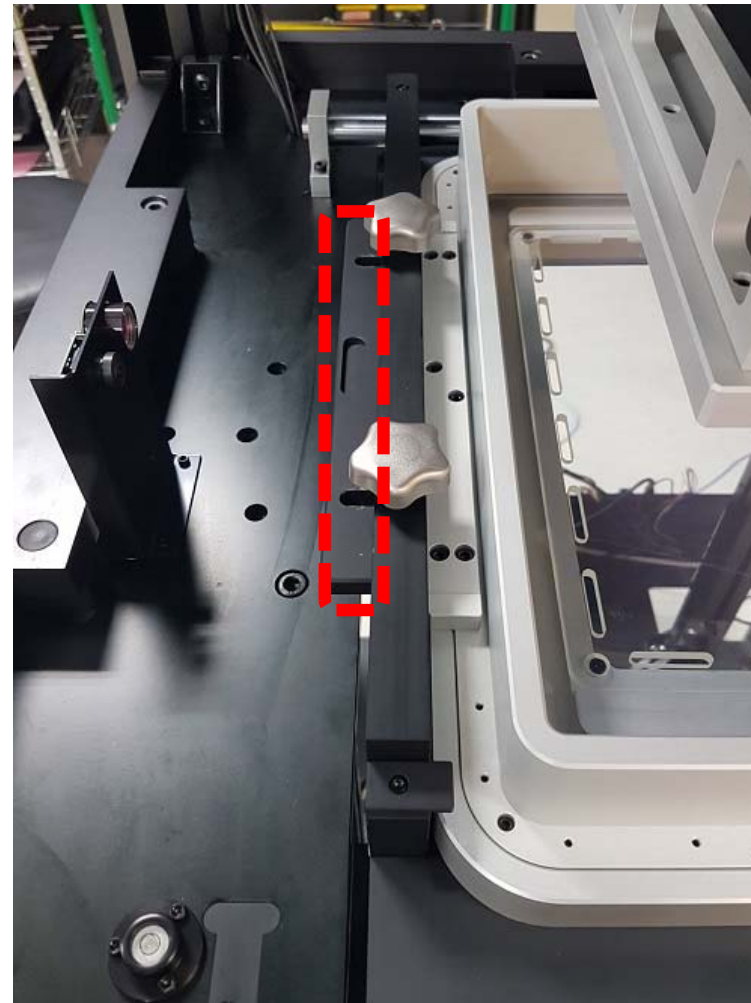

Change Tank

How to take out and install tank module?

MIIICRAFT

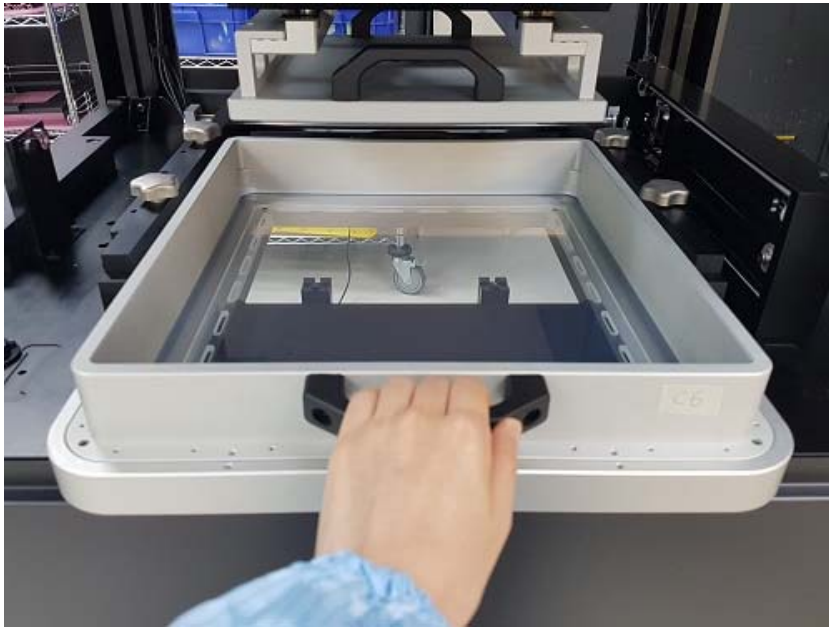

(3) Pull out the tank module--Finish



Install the tank module :

(1)Put the tank module back

(2)Return two side stoppers

(3)Turn the 4 screws clockwise until tight--Finish



Clean Teflon module

How to separate Teflon module from Tank module?

MIIICRAFT



Clean Teflon module

How to separate Teflon module from Tank module?

MIIICRAFT

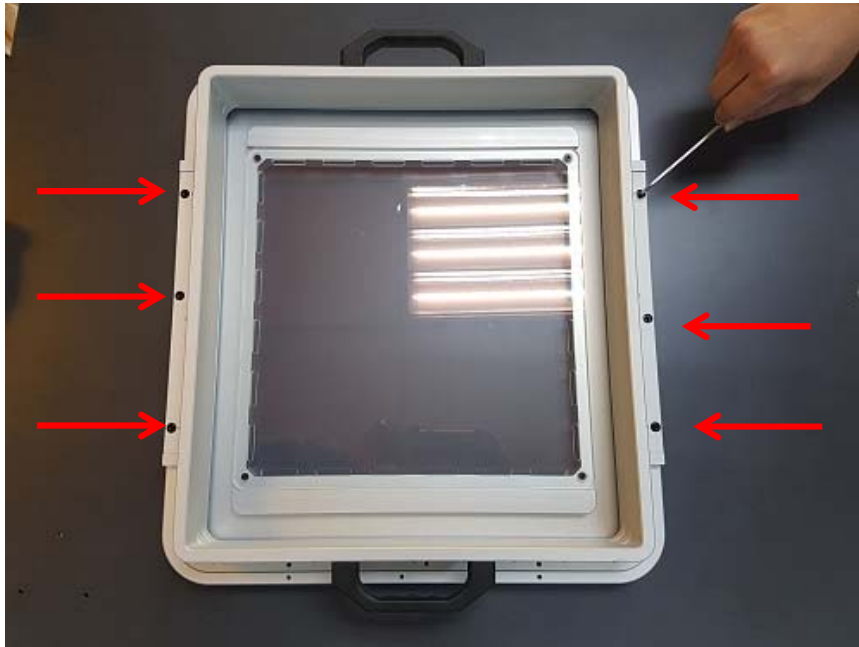

(1) Use M3 wrench to loosen 6 screws on the outside

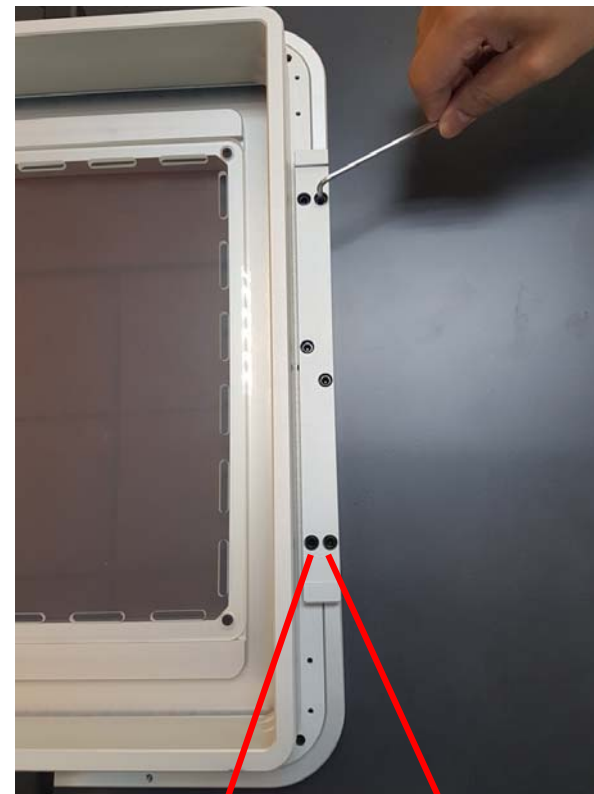

Inside screws : no need to loosen

Outside screws : need to loosen



Clean Teflon module

MIICRAFT

- (1) Pour Resin out of teflon module
- (2) Use ethanol to clean the tank
- (3) If needed, you can use tissue to clean teflon

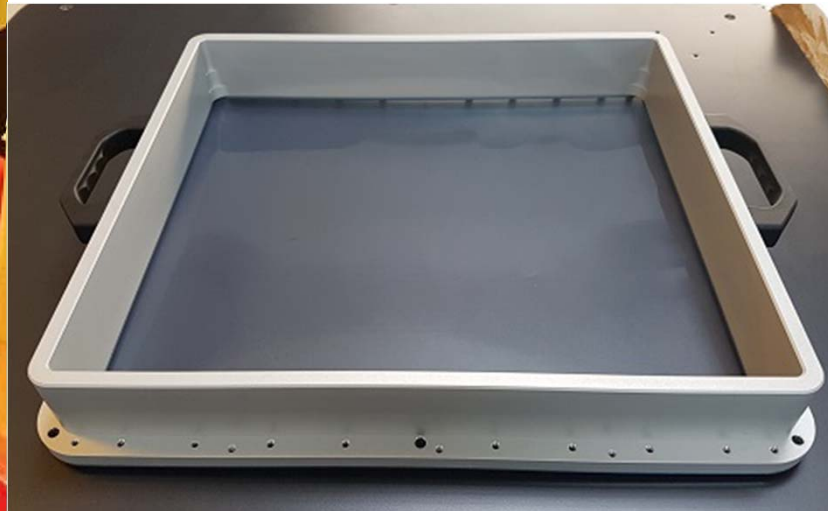

Clean Teflon module (For printing residual)

When printing failure happen, there may have some printing residual left and stick on teflon module.

Before to start another printing job, be sure to clean the printed residual out of teflon module.

- (1) Use “Clean tank” function via touch panel, it project a complete patten, the residual will be transformed into a solid layer.
- (2) Using the scrape, scoop up one side of the layer. Then carefully lift to remove solid layer from the teflon module.

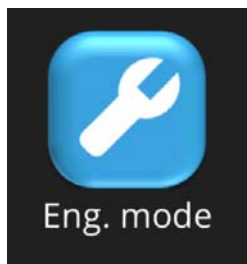

Maintenance

How to replace teflon film on a teflon module?

MIICRAFT

Teflon film is consumable, we recommend to replace teflon film when it has been using for a period, and user discover the printing quality getting worse.



Maintenance

How to replace teflon film on a teflon module?

MIICRAFT

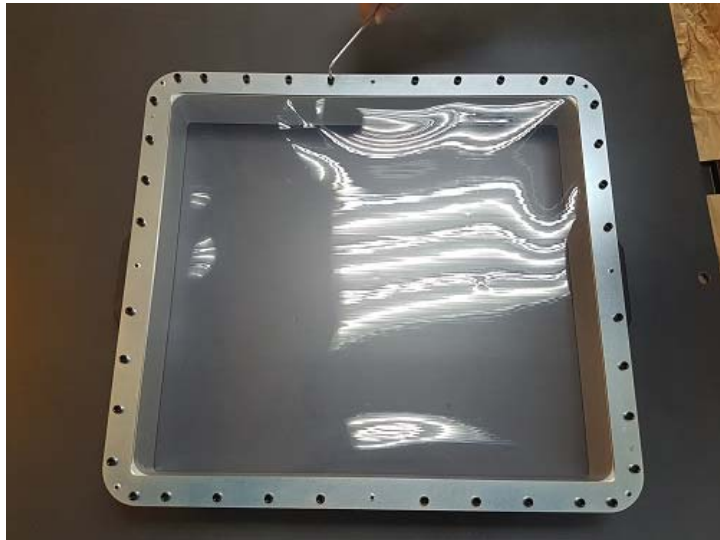

(1) Use M3 wrench to loose all screws on the Back of teflon module

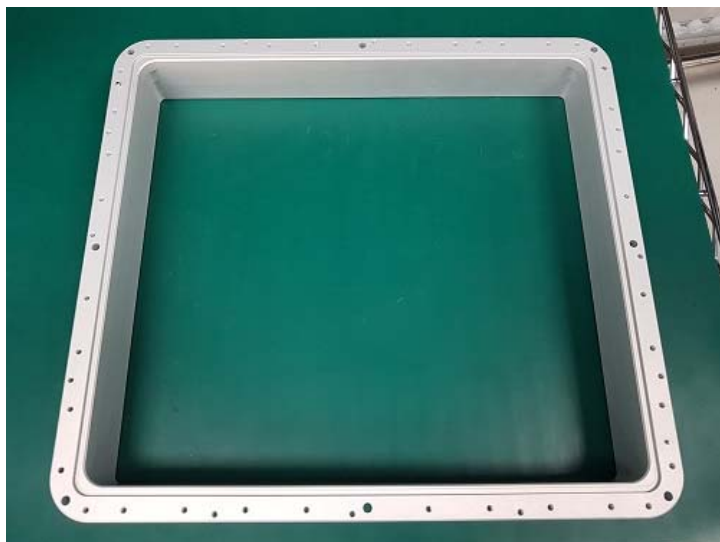

(2) Remove the screws and Rubber and teflon film



Maintenance

How to replace teflon film on a teflon module?

MIICRAFT



(3) Put the new rubber onto the gap
Make sure the rubber fit into the gap

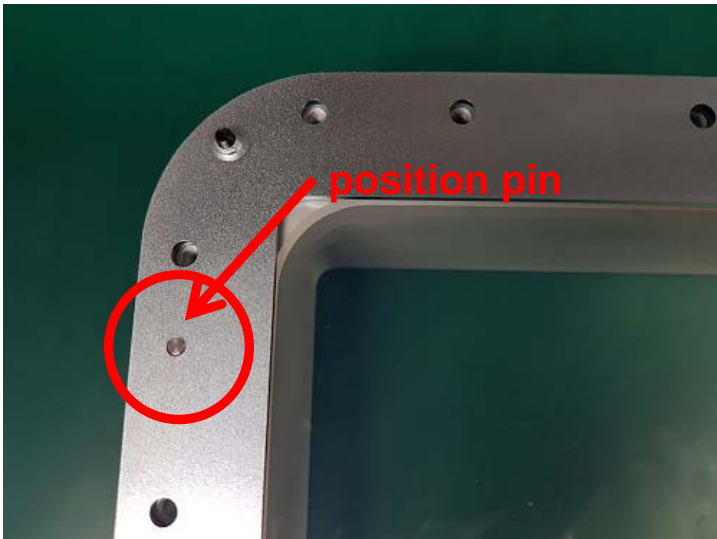
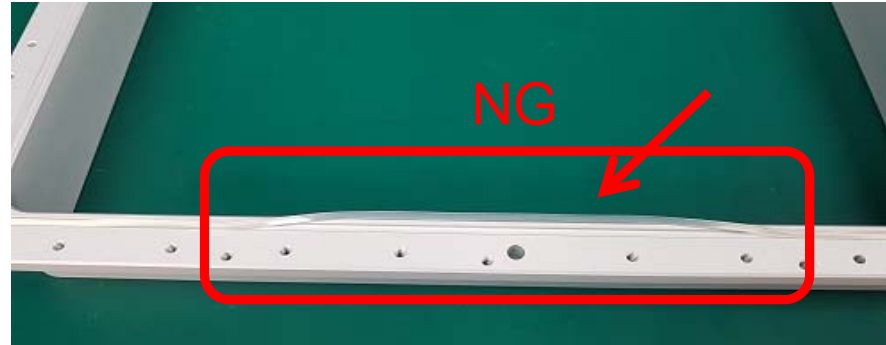

(4) Put the teflon film module, and fit with two position pin. Only one side can fit with position pin

(5) Use M4 wrench to fix all screws on the back of teflon module ----Finish.



After printing

MIICRAFT



(1) Use polypropylene (PP) scraper to wipe the excess resin on top of the build platform

(2) Take out the Build platform

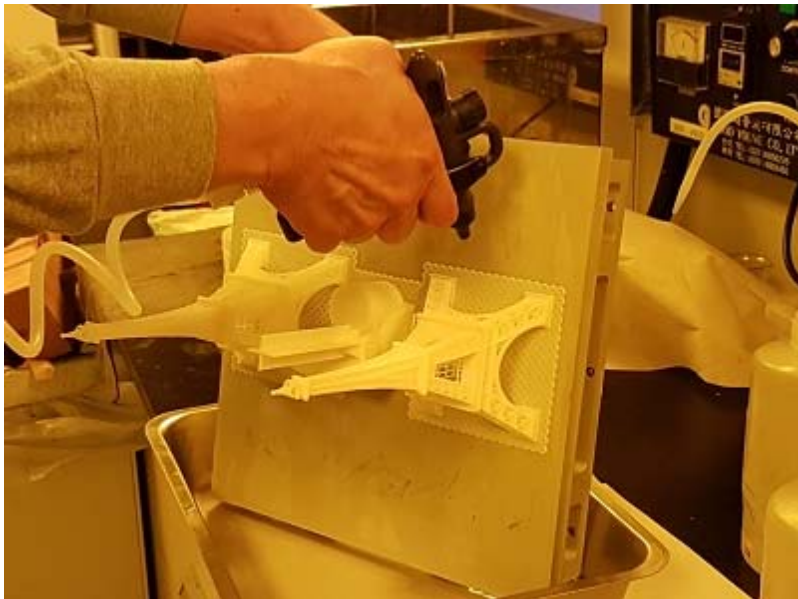

(3) Use air gun to clean the printed parts



After printing

MIICRAFT



(4) Use utility knife to separate the base



(5) Use putty knife or plastic scraper
remove the printed parts from build
platform



After printing

MIICRAFT

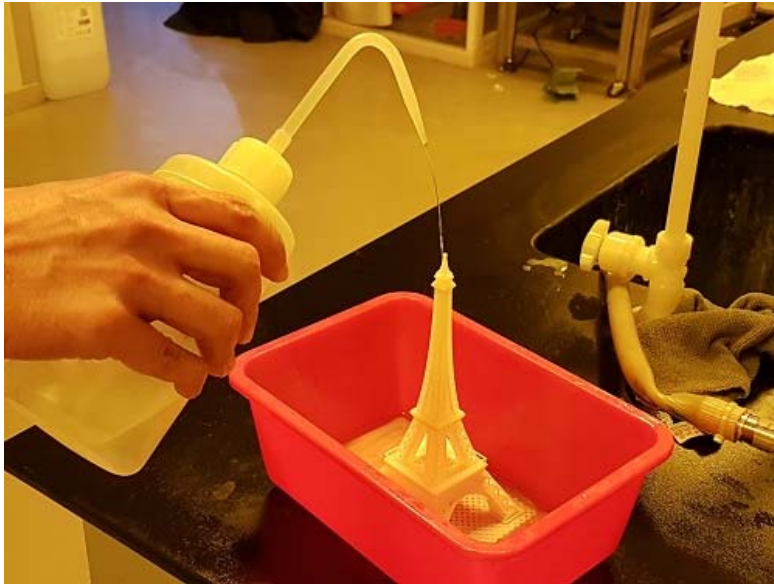

(6) Use ethanol to clean the printed parts

(7) Use water to clean the printed parts or use ultrasonic cleaning machine.

(8) Clean until the water become clear

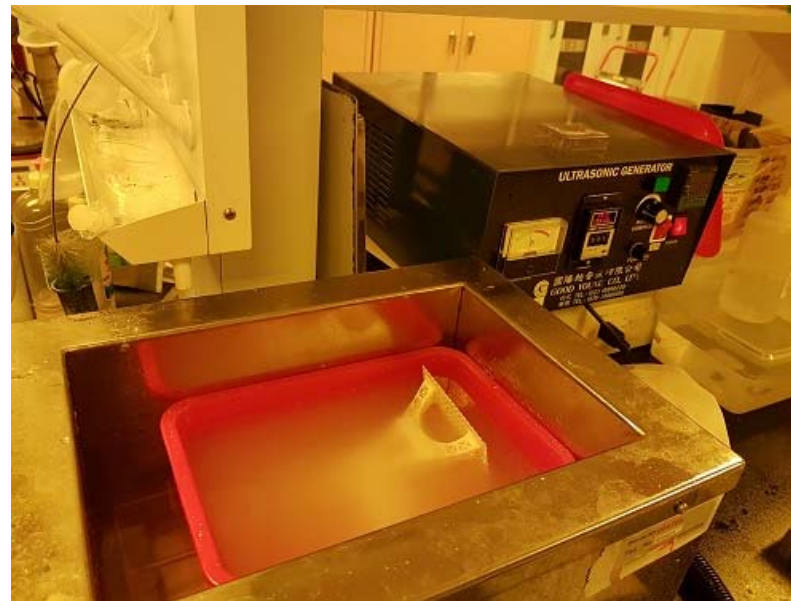

After printing

MIICRAFT

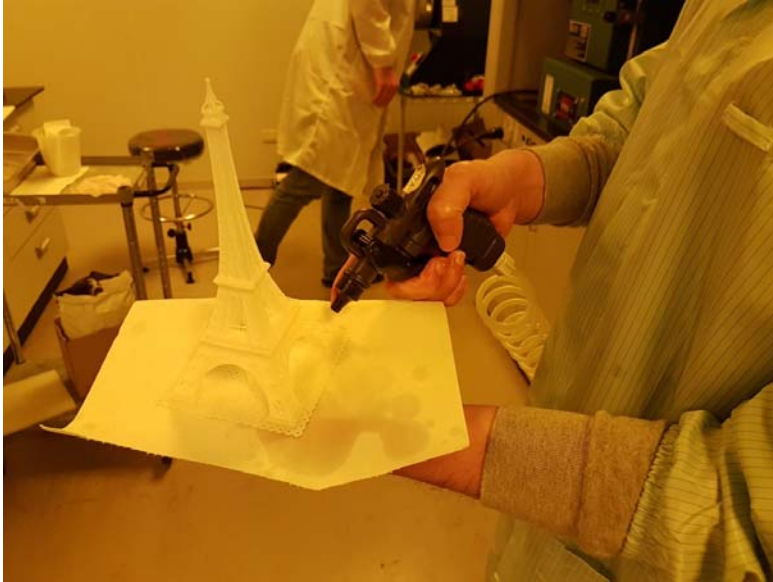

(9) Use air gun to let printed parts dry



(10) Use Curing box to cure the printed parts until it totally dry---finish



MIICRAFT

Thank you